

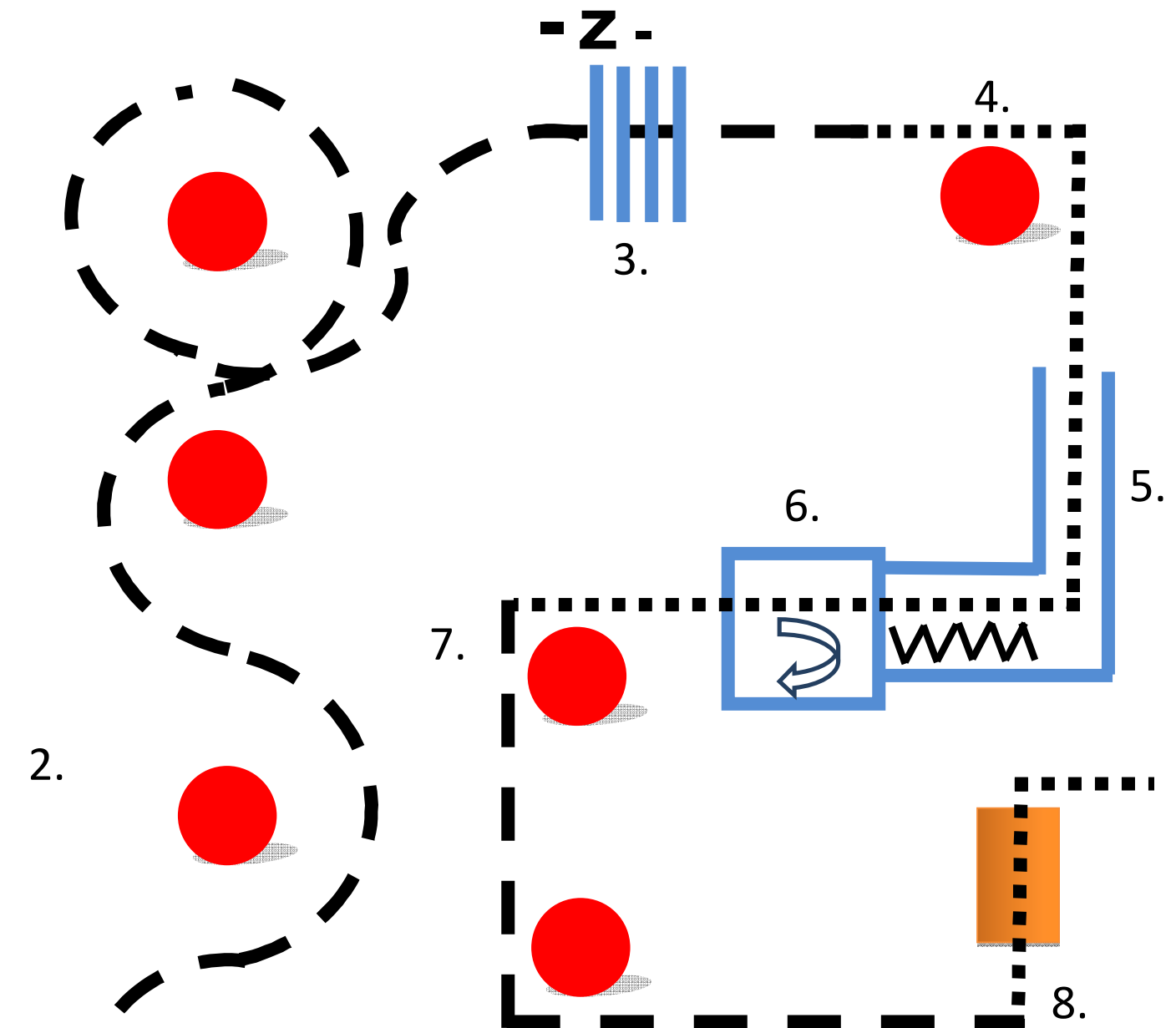

IN HAND TRAIL



- | | | |
|---------------------|---|--|
| <p>1.</p> <p>2.</p> | 



 | <p>KUŽEL</p> <p>KVALETY</p> <p>ZACOUVAT</p> <p>OBRAT</p> <p>MŮSTEK</p> |
|---------------------|---|--|
1. Krokem ke kuželu
 2. Klusem slalom a kruh kolem posledního kuželu
 3. Klusem přes kavalety
 4. U kužele přechod do kroku
 5. Krokem do L, procouvat rovnou část
 6. Krokem do čtverce, obrat o 360° vpravo nebo vlevo
 7. U kužele klus
 8. Před mostkem přechod do kroku, krokem přes mostek